

The network of specialists, for **AM professionals**

INTEGR^{AM}

Super
VibroBLAST



INTEGR^{AM}

UK



VibroBLAST AIR model	#/Ø mm Port.	Vibr.. Machine	Air cons. lt/1' bar	HP cyclone	Cyclone Met. alloy	Nr.Nozzles	Dust collector Filt.surf. cm²	Filter cleaning	Air Snorkles TOP-Blast	PneuPORT unloading port	Control board
S-VBA-DP3-060-TN-EX	Ø 98	SM3-D3-60	780x2 (6)	0,75	Steel	2	24.000	Manual	3	-	TCS-svba-1
S-VBA-DP3-060-TN-EXS-X	Ø 98	SM3-D3-60	780x2 (6)	0,75	SS	2	24.000	Autom.	3	-	TCS- svba -1
S-VBA-DP3-120-TN-EX	Ø 98	SM3-D3-120	780x2 (6)	0,75	Steel	2	24.000	Manual	3	-	TCS- svba -2
S-VBA-DP3-120-TN-EXS-X	Ø 98	SM3-D3-120	780x2 (6)	0,75	SS	2	24.000	Autom.	3	-	TCS- svba -2
Letters: -SN	SIDE-NOZZLE nozzle placed sideways										
Letters: -EX	Standard dust collector is replaced by a filter with characteristics comparable to Atex internal zone 22 – 24.000-cm² filtering surface										
Letters: -EXS	Like -EX with automatic shaking of filtering cartridges in counter-current compressed air – complete with microprocessor for cleaning intervals programming – 90.000-cm² filtering surface. Industrial vacuum cleaner 0,75KW										
Letters: -EXS2	Like -EX with automatic shaking of filtering cartridges in counter-current compressed air – complete with microprocessor for cleaning intervals programming – 90.000-cm² filtering surface. Industrial vacuum cleaner 2,2KW										
Letter: -X	The standard version includes a carbon steel cyclone; the extension X instead identifies the replacement of the standard cyclone with one in stainless steel and air/sand mixing unit in Polyurethane instead of aluminium;										
Letters: -AS	Antistatic system for polymers										
Letters: -WS	WS (Wear Sensor) – Techno Surface patent – to report, well in advance, that the working tank is worn and needs to be replaced or a new anti-abrasive coating										
Letters: -MS	Addition, on each sand supply line to the nozzle, of a media or sandblasting grit flow rate sensor (Media Flow Rate Sensor) specific for non-metallic media/grits and for vacuum systems										
Letters: -FS	Flow detector sensor complete with cables										
Letters: -SM	SIEMENS main control board instead of standard main control board (Delta)										
Appendix: -7 or -15	The standard touch screen (or HMI) is of 4,3" – on demand a bigger HMI – 7" or 15" - can be supplied. If there is the cabin, the panel is placed on the external operator side										
Letters: -AM	AM Cabin - with 7 doors and relevant RFID sensors – On the operator side of the cabin is foreseen a set-up to combine the same HMI (touch screen) foreseen on the machine										
Letters: -SB	available from October 2024; specific version with safety perimeter and access delimited by perimetral barriers										
Letters: -PL	available only combined with SB version: it allows to raise and lower the sandblasting guns' holder bars through a pneumatic piston										

The STANDARD version of S-VibroBLAST machines will be with vertical nozzles TN (Top Nozzle). Given some qualitative results obtained in specific domain (micromechanics), it is not excluded to apply the solution with lateral nozzle SN (Side Nozzle) to all clients who will demand it or where it is priority to treat pieces with a certain delicacy.

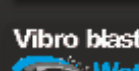
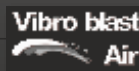

The **VibroBLAST AIR DP** (Vacuum or Depression) **VBA-DP** program is particularly competitive and versatile.

The **VibroBLAST AIR PR** (Pressure) **VBA-PR** program is particularly efficient and effective.

The **VibroBLAST WET - VBW** program is particularly specialized for some types of applications.

VibroBLAST - Air (Patent pending - I) DP (depression)

The **IntegrAM** program for dry sandblasting with vibratory finishing machines offers new horizons to your expectations. The standard **VibroBLAST - Air** (Patent pending - I) program consists of models available both with depression (**DP**) and pressure (**PR**) technology.

This brochure is only about **DP** models.

The range of machines starts with nominal capacities of 60 and 120 litres with blasting nozzles involving in 3D the mass-loaded parts in the vibratory finishing unit.

[1] **AS**: Antistatic system for polymers

[2] With **VibroBLAST** you do not use your hands to sand one piece at a time! Sandblasting takes place in mass and in **3D** inside a vibratory finishing machine (Patent pending I).



The **IntegrAM** program was born from a network of specialists, for **AM** professionals:

<https://integram.eu/en/who-we-are/>

S-VBA-DP3-120-TN-EXS-WS

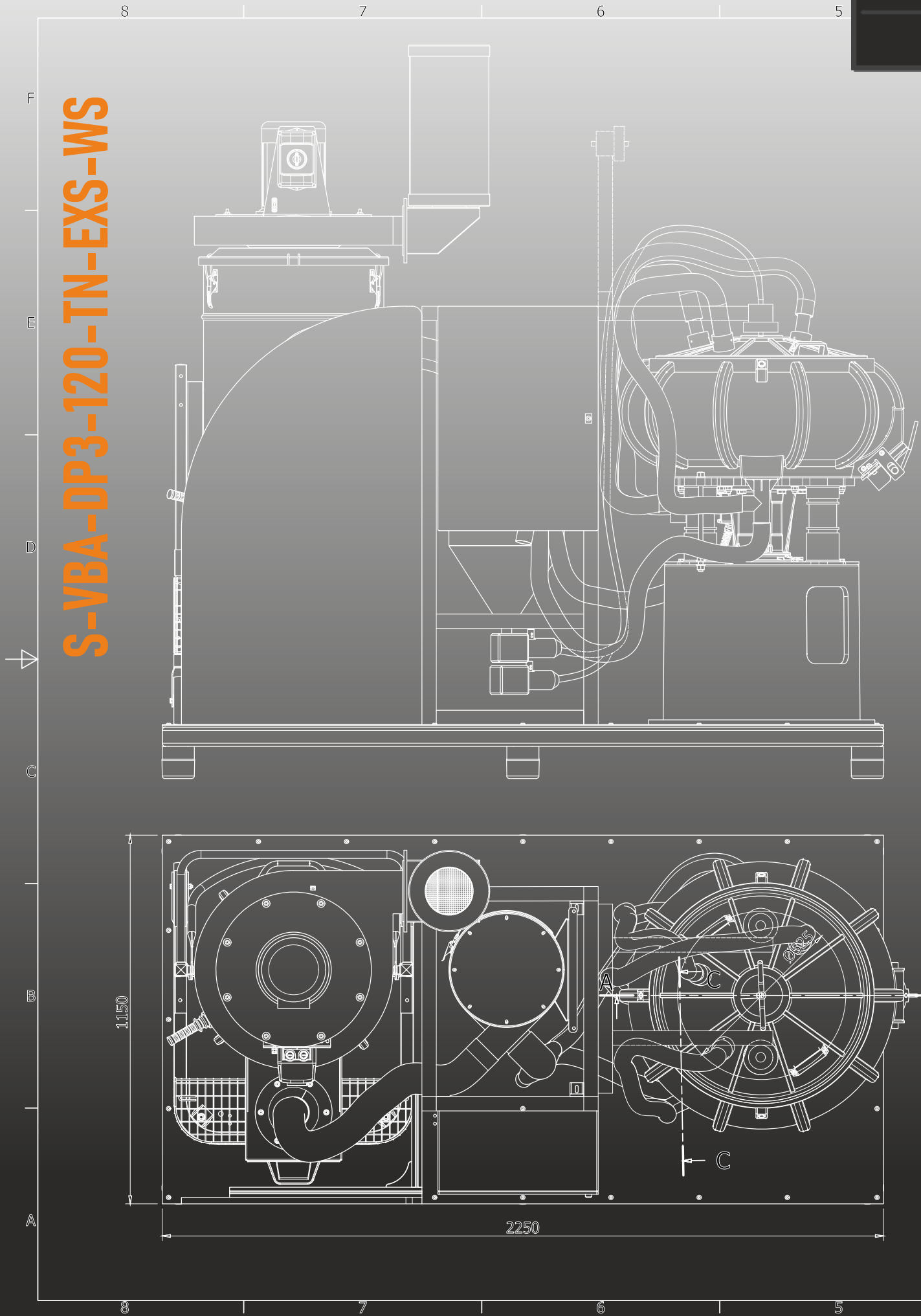

Super-VibroBLAST



S-VBA-DP3-120-TN-EXS-WS

CRONOLOGIA REVISIONI				
REV	DESCRIZIONE	DATA	AUTORE	APPROVATO
1	Modificato attacco pistole	12/01/2024	Annoni M	

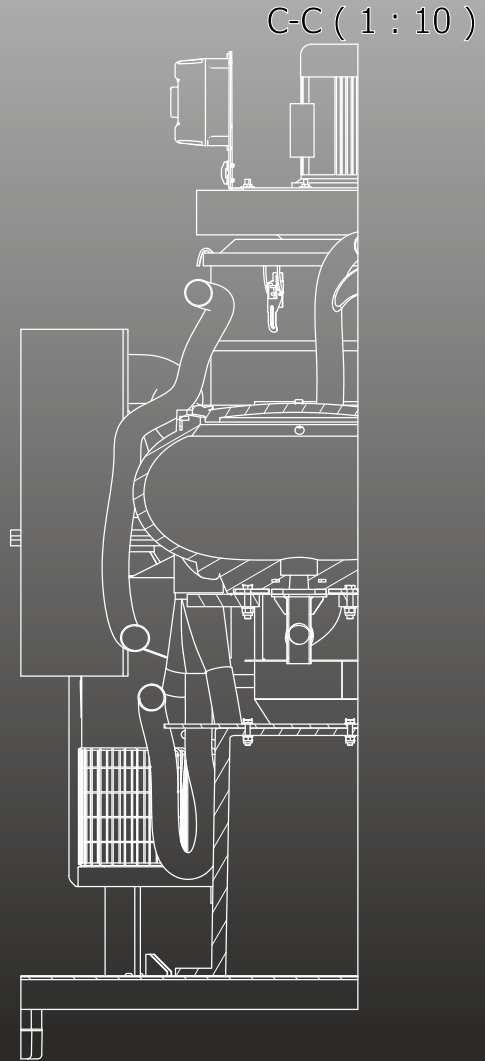
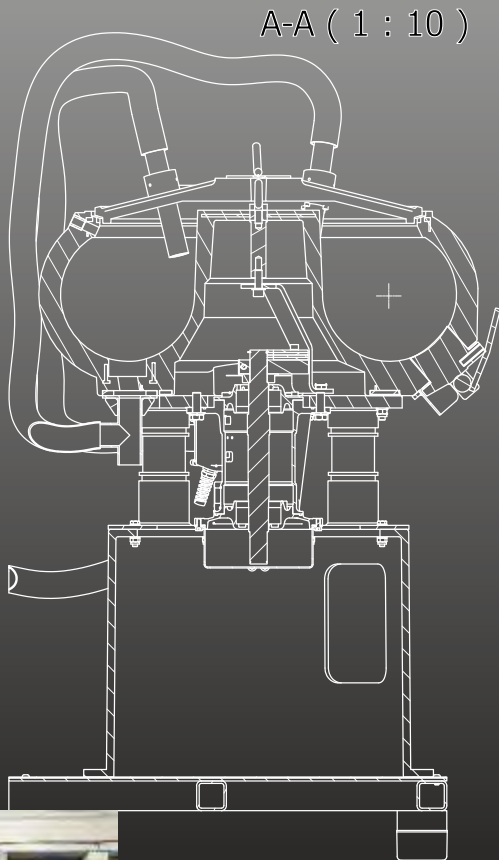

Super-VibroBLAST



S-VBA-DP3-120-TN-EXS-WS

Super-VibroBLAST

The **Super VibroBLAST Air DP** line is designed and manufactured to be supplied on a technological pallet, to make its installation immediate through a simple **plug-&-play** operation. It is enough to connect air (6 Bar) and the Euro socket to the designated line and the machine can start working as it was programmed during the try-out phase before shipment.

We take particular care of manufacturing quality, safety and ergonomics.

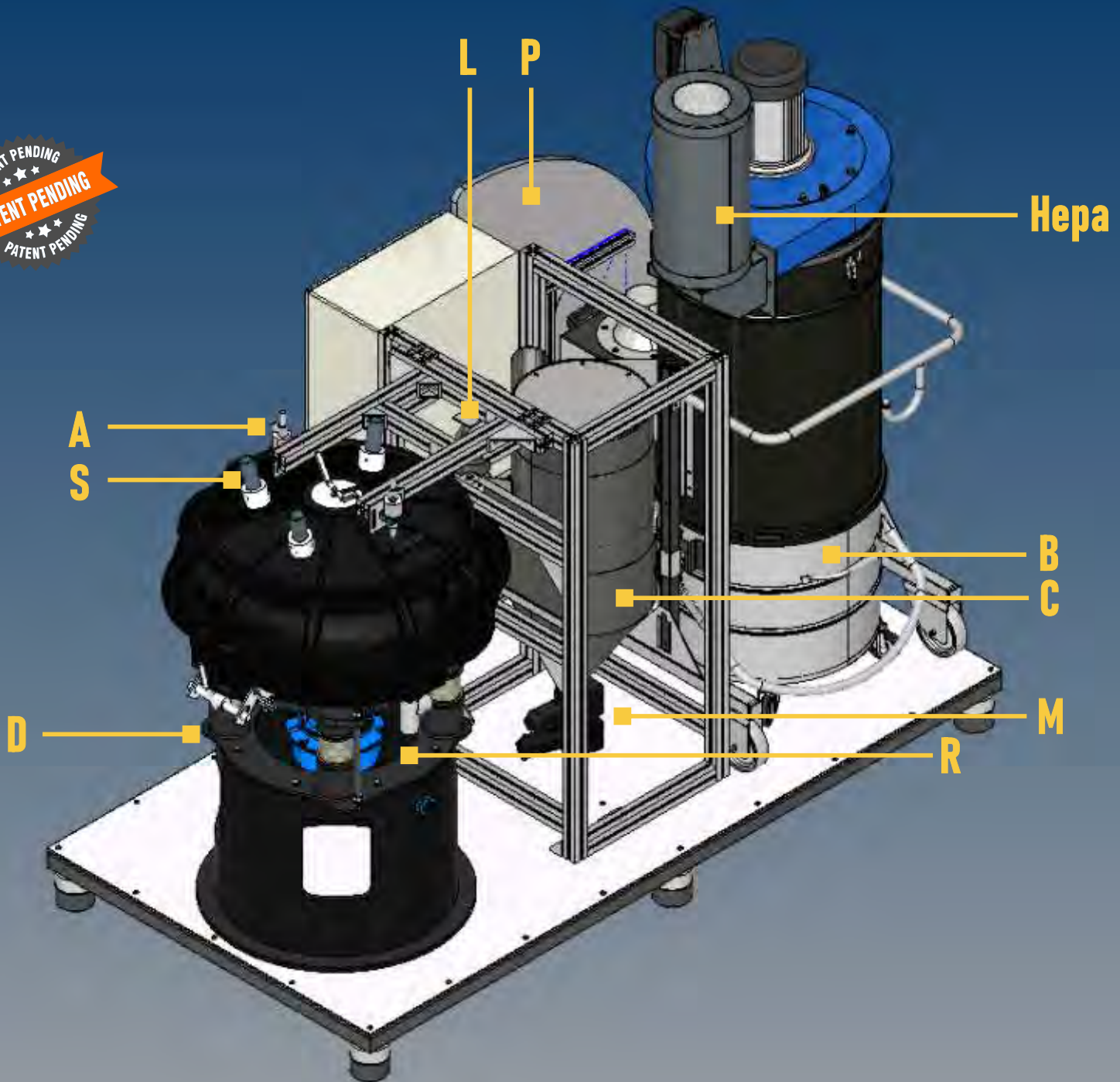
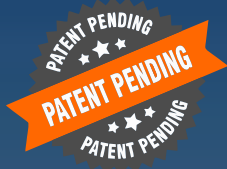

All **Super VibroBLAST Air DP** systems are the result of careful design being characterized by: A) two sandblasting nozzles; S) three air inlet snorkels; B) filtered dust collection container - on the same side as C) cyclone loading door for sandblasting media; D) side for total discharge from the tank door; M) two air-sand mixing groups (see specifications on page 11); R) three connections for filtered sand discharge, in correspondence with the three filters on the tank bottom; L) InterLock - safety lock on shot nozzles support bars; P) protective panel; Hepa) the filter aspirator is equipped with a standard filter M (1 micron) and an outlet silencer.

S-VBA-DP3-120-TN-EXS-WS

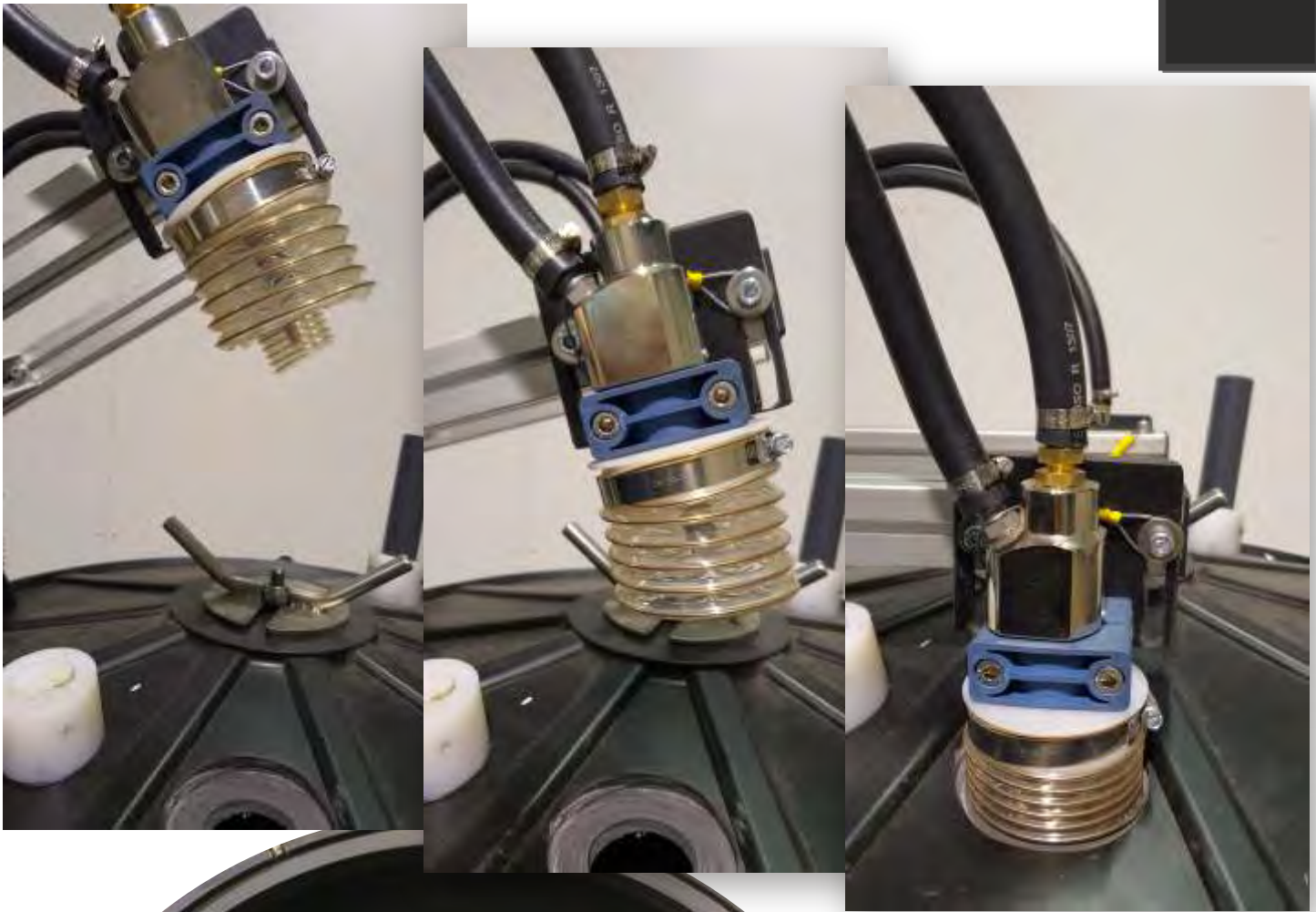

2 «IN»
3 «OUT»

Super-VibroBLAST

The Super VibroBLAST Air DP system includes two tilting bars to support the two sandblasting nozzles. In this representation the bars are raised, an operation performed manually by the operator only at the end of the work cycle - in this case the safety interlock releases the constraint to be able to tip over the bars upwards. The operator will thus be able to open the access cover to the work tank and start it where required for loading and unloading operations, without the risk to activate the sandblasting nozzles - they are in fact inhibited by the interlock sensor.

Once the cover is closed and the bars are lowered with the interlock active, the sandblasting nozzles can be activated in complete safety - there are two protective bellows around the cover upper holes;



Super-VibroBLAST

All **Super VibroBLAST Air DP** systems have been designed to ensure excellent aspiration and filtration, with ATEX Zone level 20 or 22 inside the aspiration unit.

To increase its performance, the basic machine is painted with a new type of glossy paint to minimize dust sticking to the internal walls. The air exhaust collector is equipped with a silencer. **Super VibroBLAST** systems can be equipped with the automatic shaking – all three exhaust collectors of relevant filters on the bottom of the tank are equipped with an air inlet in order to facilitate sandblasting powders and grains evacuation. It is always recommended to use dried compressed air (without moisture).

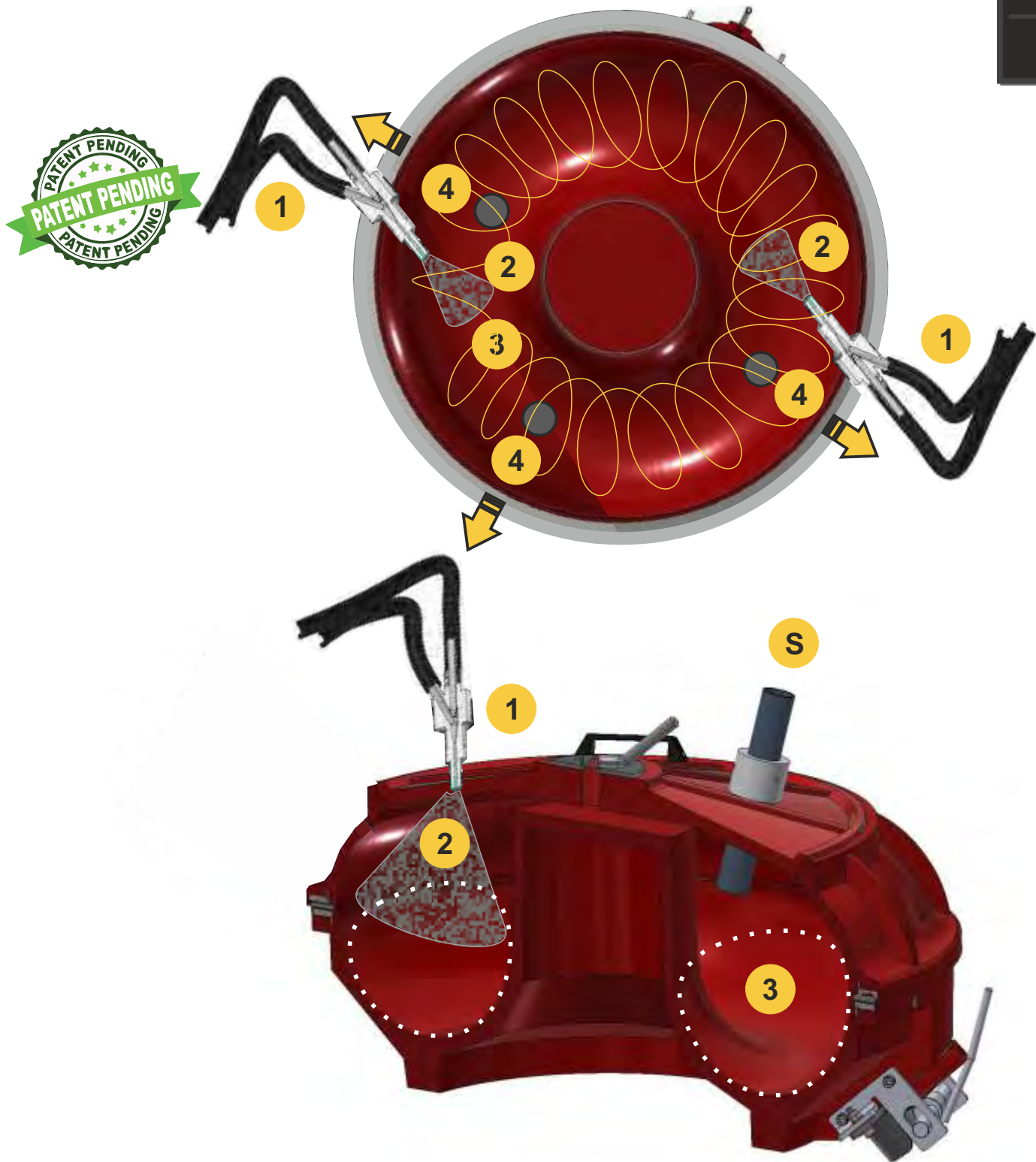

Super-VibroBLAST

All **Super VibroBLAST Air DP** systems have TN (Top Nozzle) sandblasting nozzles placed in the cover upper area, to involve from above the treated components, while they rotate three-dimensionally, clockwise, inside the circular vibro-blasting tank.

At the apex of the cover, we therefore have the nozzle [1] with vertical adjustment [2], placed above the mass being processed [3]. The cover S-VBA includes 3 snorkels [S].

The presence of 3 discharge filters [4], instead of the single filter in the basic version, allows the Super VibroBLAST to carry out treatments with pressures of up to 6 bar with the certainty of a total and effective discharge of the sandblasting media.

At the same time, the components subjected to vibro-sandblasting meet the nozzles every 180°, instead of every 360° as in the basic version.

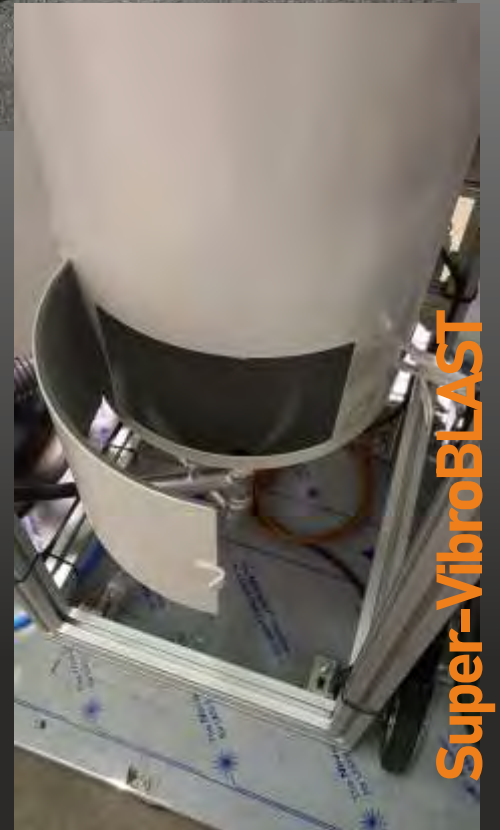
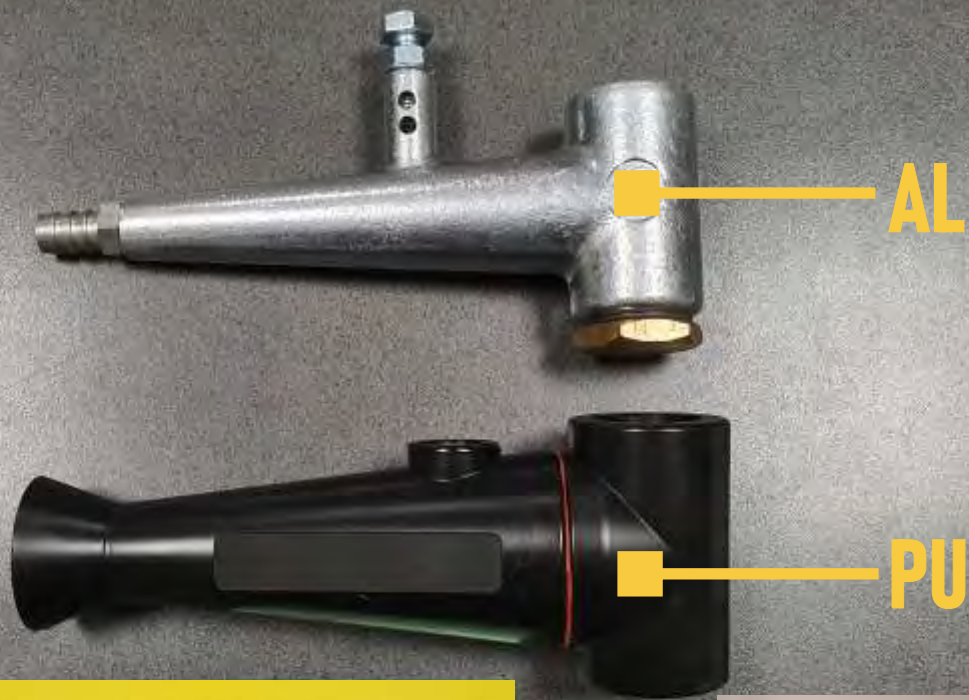

All **Super VibroBLAST Air DP** systems have been designed to ensure, where required, a stainless-steel cyclone feeding the sandblasting media, as an alternative to that of painted carbon steel. This happens, for example, in sectors such as medical, food or all contexts in which this solution is necessary.

At the same time, with the standard cyclone in painted carbon steel, the (2) air-sand mixing groups mounted under the lower cone are made of aluminium.

In the version with stainless-steel cyclone, the two mixing groups are made of non-toxic and anti-abrasive polyurethane, with stainless-steel fittings and inserts.

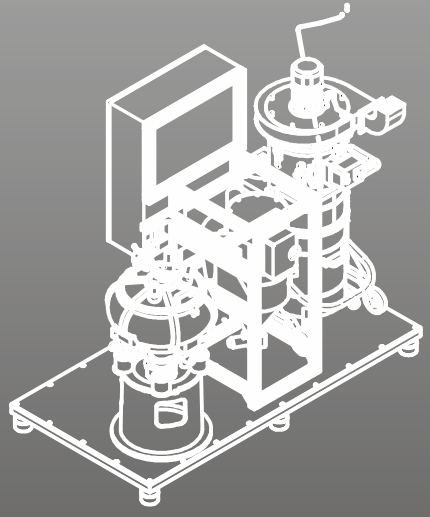
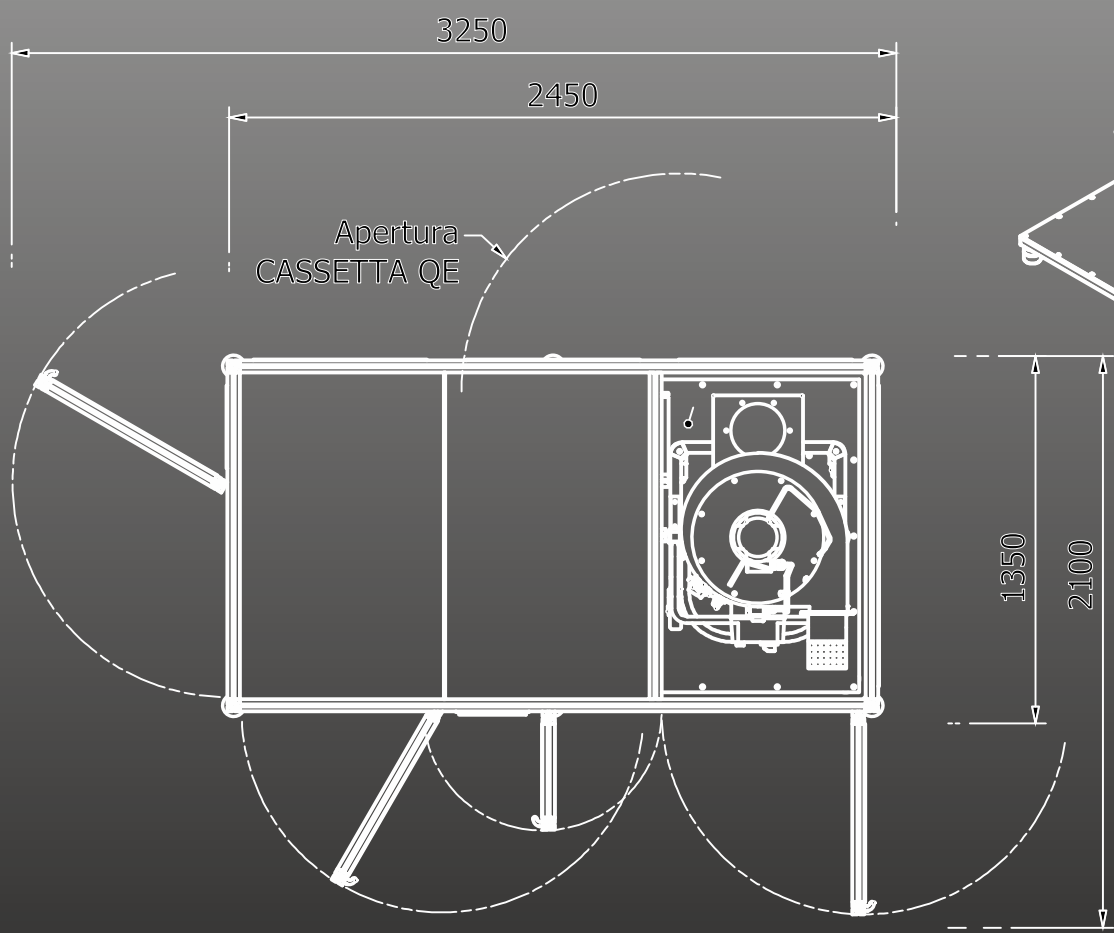
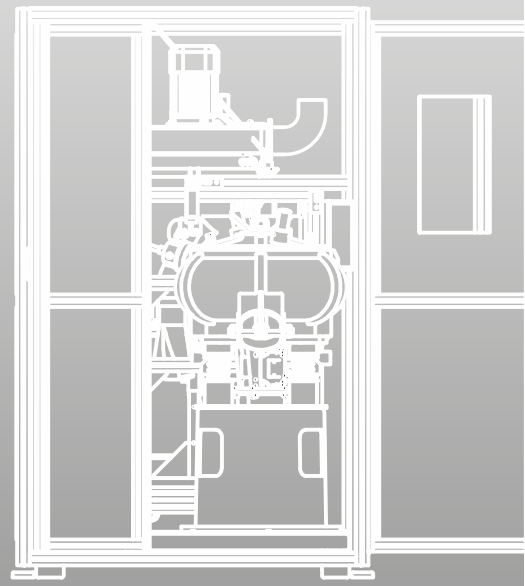
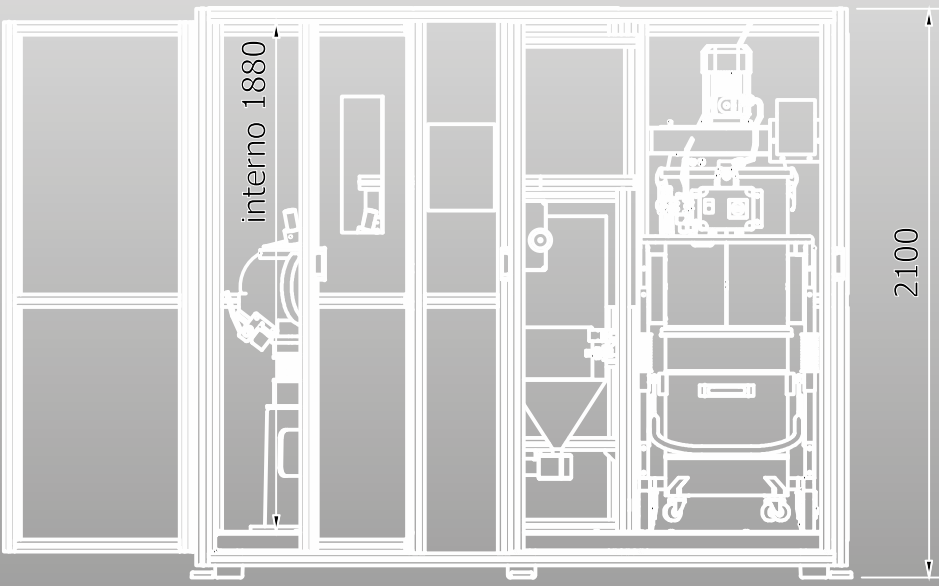

Super-VibroBLAST

S-VBA-DP3-60-TN-EXS-WS-AM

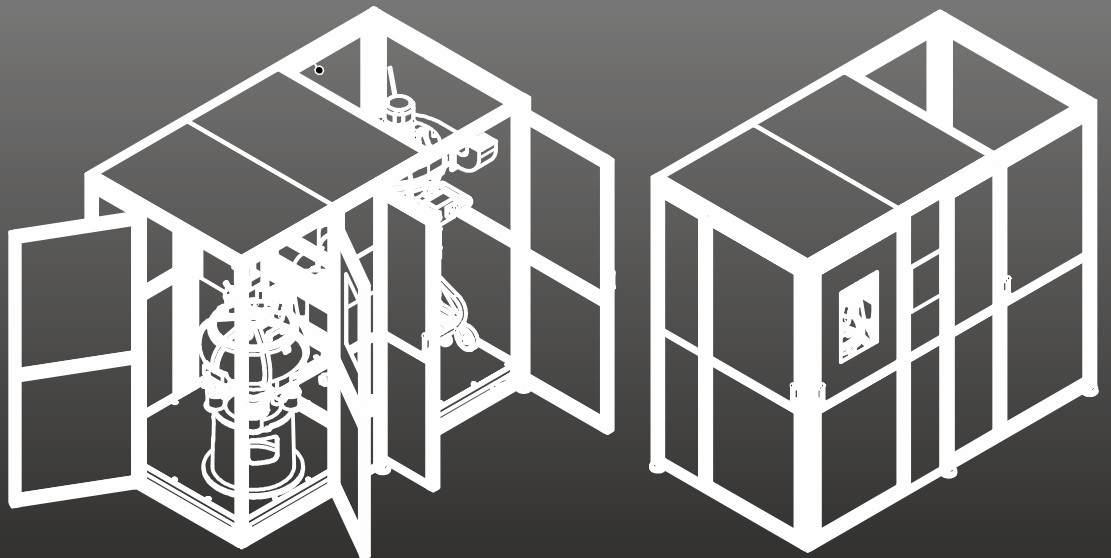
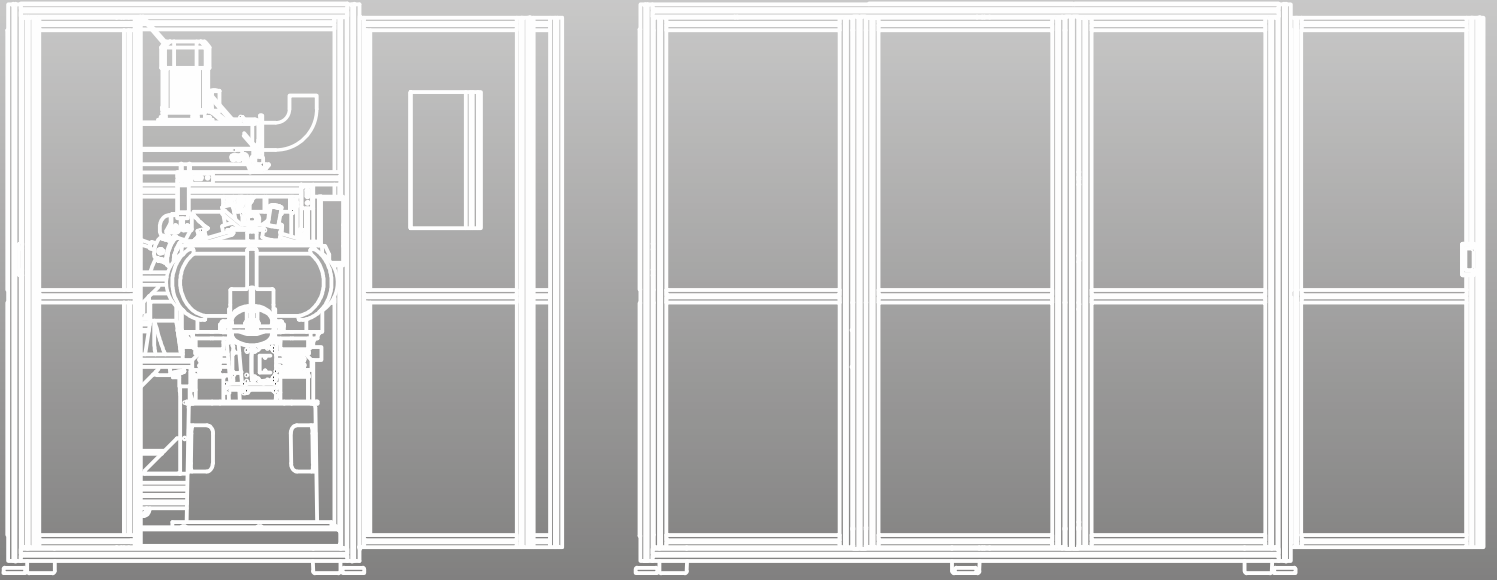

Super-VibroBLAST

S-VBA-DP3-60-TN-EXS-WS-AM



Super-VibroBLAST



Super-VibroBLAST



Super-VibroBLAST strong points:

- 1. Reducing cycle time**
- 2. Reaching concave surfaces better than ever**
- 3. Powerfull aspirator/filter**
- 4. Double flow, powerful final blowing-out**

The network of specialists, for **AM professionals**

AM

INTEGR

Super
VibroBLAST

This brochure is for guidance only. Its content can change depending on the development of the product.

#0225-SupeVIBROBLAST-DP-I-AM-[uk]

UK

IntegrAM

The network of specialists, for **AM professionals**

The IntegrAM program and network are coordinated by:

Techno Surface Sas - Office and Warehouse:

Via Rocolo Aldè 1, 23811 Ballabio (LC) - Italy

Tel. IntegrAM: +39 349 29 23 689

e-mail: integram-team@gmail.com

web: <https://integram.eu>

INTEGR^{AM}