

The network of specialists, for **AM professionals**

INTEGR^{AM}

BLAST
OK!





BLAST-OK è una linea di classiche cabine di sabbiatura ad aria compressa, sia di tipo classico a depressione (venturi) sia di tipo a pressione (compatibili anche con graniglie metalliche). In uno scenario di mercato che spazia da soluzioni ultra-economiche, spesso di dubbia qualità e sicurezza, a prodotti estremamente sofisticati ma molto cari, la linea di prodotti **BLAST-OK** si colloca in una fascia di mercato con prezzi competitivi e aspetti fondamentali come sicurezza e qualità assolutamente **OK!**

BLAST-OK is a line of classic compressed air sandblasting cabins, both the classic vacuum type (venturi) and the pressure type (also compatible with metal shot).

In a market scenario that ranges from ultra-economical solutions, often of dubious quality and safety, to extremely sophisticated but very expensive products, the **BLAST-OK** product line is placed in a market segment with competitive prices and fundamental aspects such as safety and quality that are absolutely **OK!**

BLAST OK!



IntegrAM è la tecnologia all'avanguardia che si occupa di integrare post-processi e finitura delle superfici legati all'AM (acronimo di "Manifattura Additiva"). Integriamo le nostre conoscenze nell'ambito della finitura delle superfici, con approccio interdisciplinare e spirito di innovazione, efficientamento ed automazione delle tecnologie dei post-processi. IntegrAM è un network di specialisti che ha realizzato un programma di soluzioni innovative, originali e competitive per i professionisti dell'AM.

IntegrAM is the cutting-edge technology that deals with the integration of post-processes and surface finishing related to AM (acronym for "Additive Manufacturing").

We integrate our knowledge in the field of surface finishing, with an interdisciplinary approach and a spirit of innovation, efficiency and automation of post-process technologies. IntegrAM is a network of specialists who have created a program of innovative, original and competitive solutions for AM professionals.



The IntegrAM program was born from a network of specialists, for AM professionals:
Il programma IntegrAM nasce da un network di specialisti, per i professionisti dell'AM:
<https://integram.eu/en/who-we-are/>



BLAST-OK è una delle possibili soluzioni di post processo e preparazione della superficie di componenti, soprattutto pesanti e compatti, come quelli in metallo originati tramite «Additive Manufacturing» o Fabbricazione Additiva.

BLAST-OK is one of the possible post-processing and surface preparation solutions for components, especially heavy and compact ones, such as metal ones created through «Additive Manufacturing».

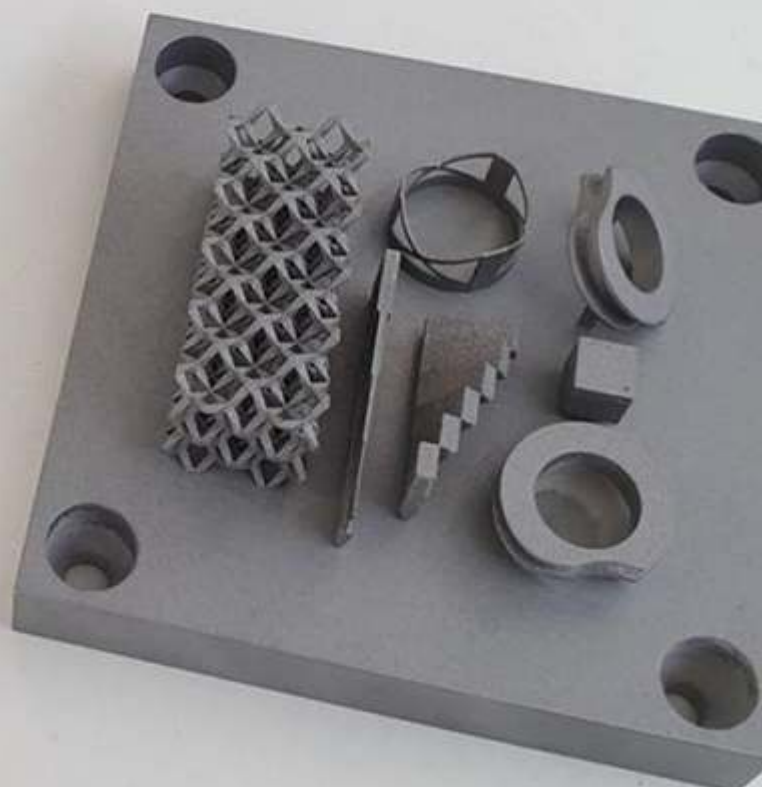
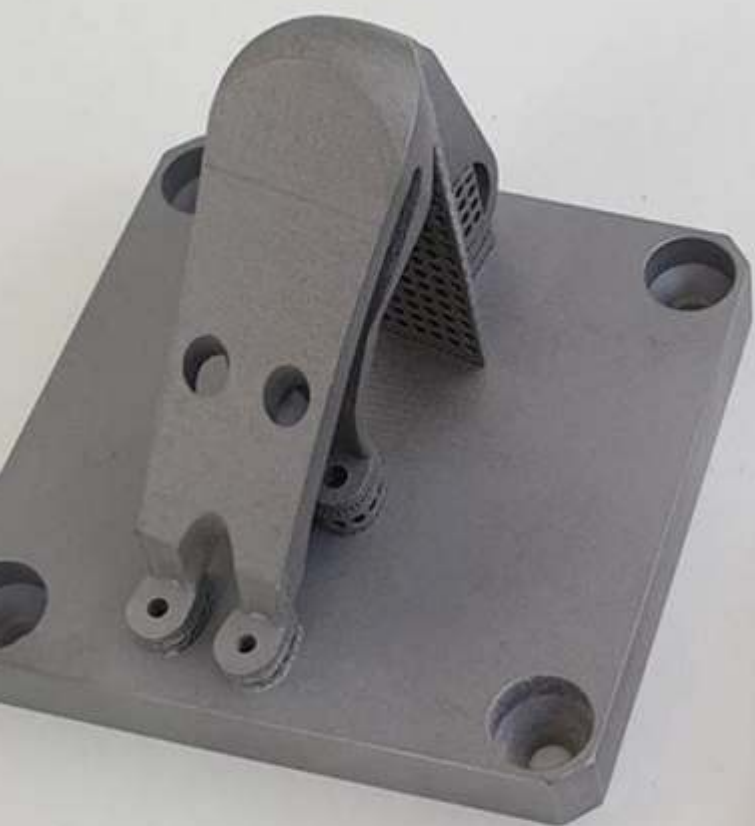

«Colors OK»
Vedi a pag. 11 | See page 11



| Modello Model | BOK-LAB-AIR-DP-CAB-100 |
|---|----------------------------------|
| Dimensioni cabina Cabin dimensions | 600x520x230mm |
| Dimensioni D'ingombro Overall dimensions | 660x530x500mm |
| Pesi Weight | 38kg |
| Piano di lavoro Work plan | lamiera forata Perfired sheet |
| Illuminazione Lighting | Led |
| Consumo d'aria Air consumption | 340 l/min a 7atm |
| Alimentazione Power supply | 220V - 50Hz |

Sabbiatrice **IntegrAM** ad aria compressa utilizzata per il trattamento delle superfici: legno, metallo, vetro, ceramica ecc.

Colpendo la superficie da trattare con un abrasivo appropriato, si rigenera la superficie per un trattamento successivo. La sabbiatrice è ideale per la pulizia di piccole superfici.

IntegrAM's compressed air sandblasting machine is used for the surface treatment of: wood, metal, glass, ceramic, etc.

By hitting the surface to be treated with a suitable abrasive, the restored surface is ready further treatment.

The sandblasting machine is ideal to clean small surfaces.



1400W



Tubo flessibile, antistatico in metallo
Antistatic and flexible pipe in metal



Filtro lavabile
Washable filter



Filtro per polveri fini
Filter for fine powders



Filtro lavabile
Washable filter



Coprifiltro di facile apertura
Easy opening filter-cover



Sacco copri filtro
Bag to cover filter



Doppio comparto con rete filtrante
Double section with filtering net



Apertura rapida
Quick opening

Aspiratore filtro VD+ aspiratore dotato di un doppio serbatoio di raccolta 14 + 14 litri. Potenza 1400 Watt max, Depressione 230 mbar, Depressione 23 kPa, Potenza di Aspirazione 68 l/s. Peso 9 Kg Dimensioni imballo 37 x 37 h 71 cm.

Questa macchina offre tre livelli di protezione in più rispetto al modello base - è raccomandata per uso discontinuo e/o in combinazione con eventuali soluzioni tipo VACU-BOX.

VD+ suction filter, vacuum cleaner with a double collection tank of 14 + 14 liters. Power 1400 watts max, 230 mbar Depression, Depression 23 kPa suction power of 68 l / s. Weight 9Kg, Package dimensions 37 x 37 h 71 cm.

This machine offers three levels of protection than the basic model - is recommended for discontinuous use, and/or in combination with any eventual VACU-BOX type of solutions.

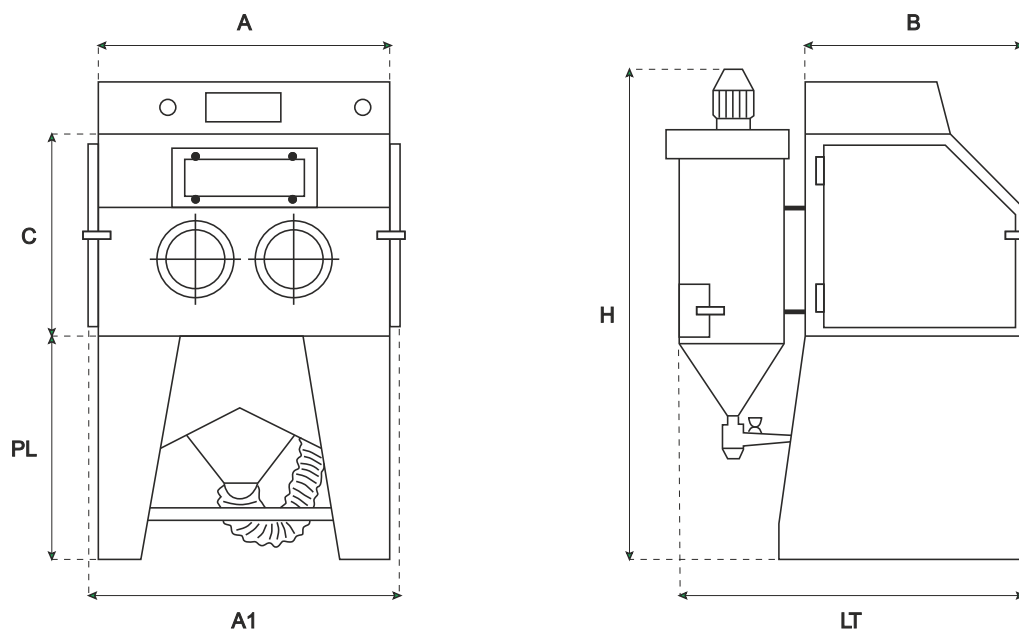

| Modello Model | BOK-AIR-DP-CAB-330 | BOK-AIR-DP-CAB-420 | BOK-AIR-DP-BAB-740 | BOK-AIR-DP-CAB-1260 |
|---|-----------------------------|------------------------------|-------------------------------|-------------------------------|
| Misure zone di lavoro work surface dimensions | (AxBxC) 750x600x730mm | (AxBxC) 880x600x780mm | (AxBxC) 1180x800x780mm | (AxBxC) 1440x1090x800mm |
| Altezza piano di lavoro Working surface height | (H) 800/900mm | (H) 800/900mm | (H) 800/900mm | (H) 800/900mm |
| Misure di ingombro Overall dimensions | (A1-LT-H) 970x930x1800mm | (A1-LT-H) 920x1250x1900mm | (A1-LT-H) 1240x1300x1900mm | (A1-LT-H) 1480x1600x1900mm |
| Pesi Weight | 80kg | 130kg | 190kg | 280kg |
| Consumo di aria compressa Air consumption | 600 - 800 - 1200 | 600 - 800 - 1200 | 600 - 800 - 1200 | 600 - 800 - 1200 |
| Iniettori Injectors d. 3,0-3,5-4,0 | | | | |
| Potenza aspiratore Power suction | 380V 0,25KW | 380V 0,75KW | 380V 0,75KW | 380V 0,75W |
| Assorbimento energia elettrica Power absorpion | 0,5KW | 1,0KW | 1,0KW | 1,0KW |
| Illuminazione cabina Cabin lighting | Alogena/Halogen 230V | Alogena/Halogen 230V | Alogena/Halogen 230V | Alogena/Halogen 230V |



BOK-AIR-DP-CAB-330



BOK-AIR-DP-CAB-420



BOK-AIR-DP-CAB-740



BOK-AIR-DP-CAB-1260

«Colors OK»
Vedi a pag. 11 | See page 11

Le pallinatrici-sabbiatrici a cabina **IntegrAM** sono state studiate e prodotte per garantire molteplici lavorazioni nel campo della finitura dei metalli: sabbatura decorativa, finitura, indurimento metalli, pallinatura, sbavatura, trattamenti superficiali, pulizia. La lavorazione sui pezzi viene variata a seconda del tipo di abrasivo utilizzato: corindone, sabbie, microsferi di vetro, granuli sintetici o vegetali, abrasivi metallici.

Per ottenere la massima funzionalità ogni macchina può essere corredata con i seguenti accessori: tavola rotante manuale, carrello di caricamento, ciclone rigenera abrasivo, filtro a cartucce autopulenti.

Shot blasting-sandblasting cabins **IntegrAM** are designed and produced to guarantee a wide range of processes in the metal finishing field: decorative sandblasting, finishing, metal hardening, shot blasting, deburring, surface treatments and cleaning. The processing on pieces varies according to the type of the used abrasive: aluminum oxide, sand, glass beads, synthetic or natural granules or metallic abrasives.

For maximum functionality, each machine can be equipped with the following accessories: manual rotating table, loading cart/trolley, centrifugal abrasive regenerator, self-cleaning filter cartridge.



BOK-AIR-PR-CAB-420



BOK-AIR-DP-CAB-740



BOK-AIR-DP-CAB-1260

«Colors OK»
Vedi a pag. 11 | See page 11

Le cabine di pallinatura e sabbiatura "a pressione" IntegrAM, a differenza delle tradizionali cabine "a depressione", abbreviano i tempi di lavorazione e incidono con più facilità il pezzo da trattare.

Le cabine a pressione vengono accessoriate con rivestimento in gomma antiusura per aumentarne la resistenza.

Un riduttore di pressione consente di regolare la velocità di uscita dell'abrasivo con i seguenti vantaggi:

- possibilità di utilizzare il sistema su diverse superfici (alluminio, ferro, vetro, acciaio inox, ecc.)
- ottenere incisioni profonde o lucidature leggere
- evitare di intaccare il pezzo.

"Pressure" shot blasting and sandblasting cabins IntegrAM, unlike to traditional "depression" cabins, shortens the processing time and cut engrave the piece to be treated more easily.

Pressure cabins are equipped with a wear resistant rubber coating to increase their resistance.

A pressure reducer allows to adjust the abrasive output pressure offering the following advantages:

- possibility to use the system on various surfaces (aluminium, iron, glass, stainless steel, etc.)
- achieves deep incisions or light polishing
- avoids damaging the piece.

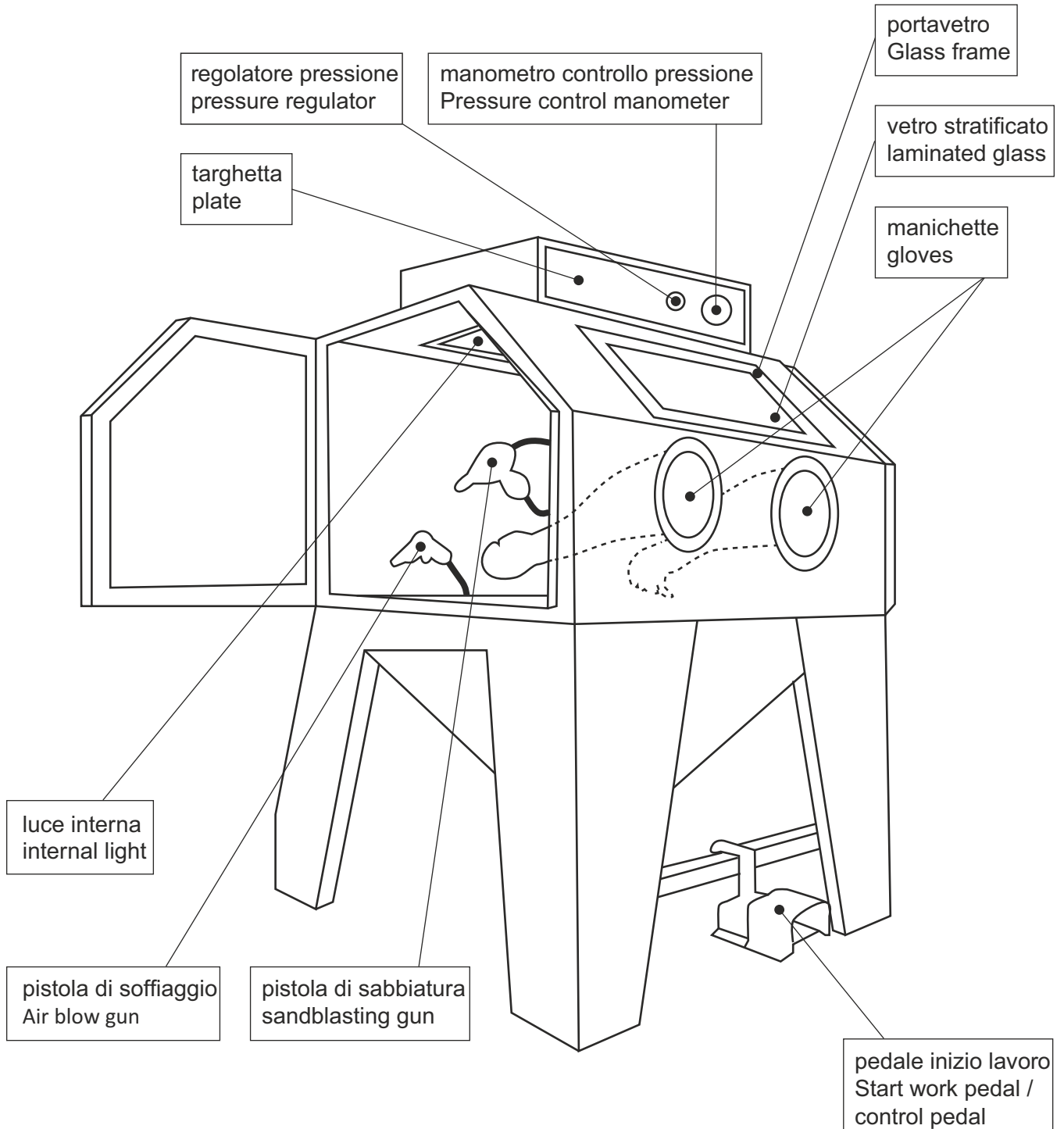

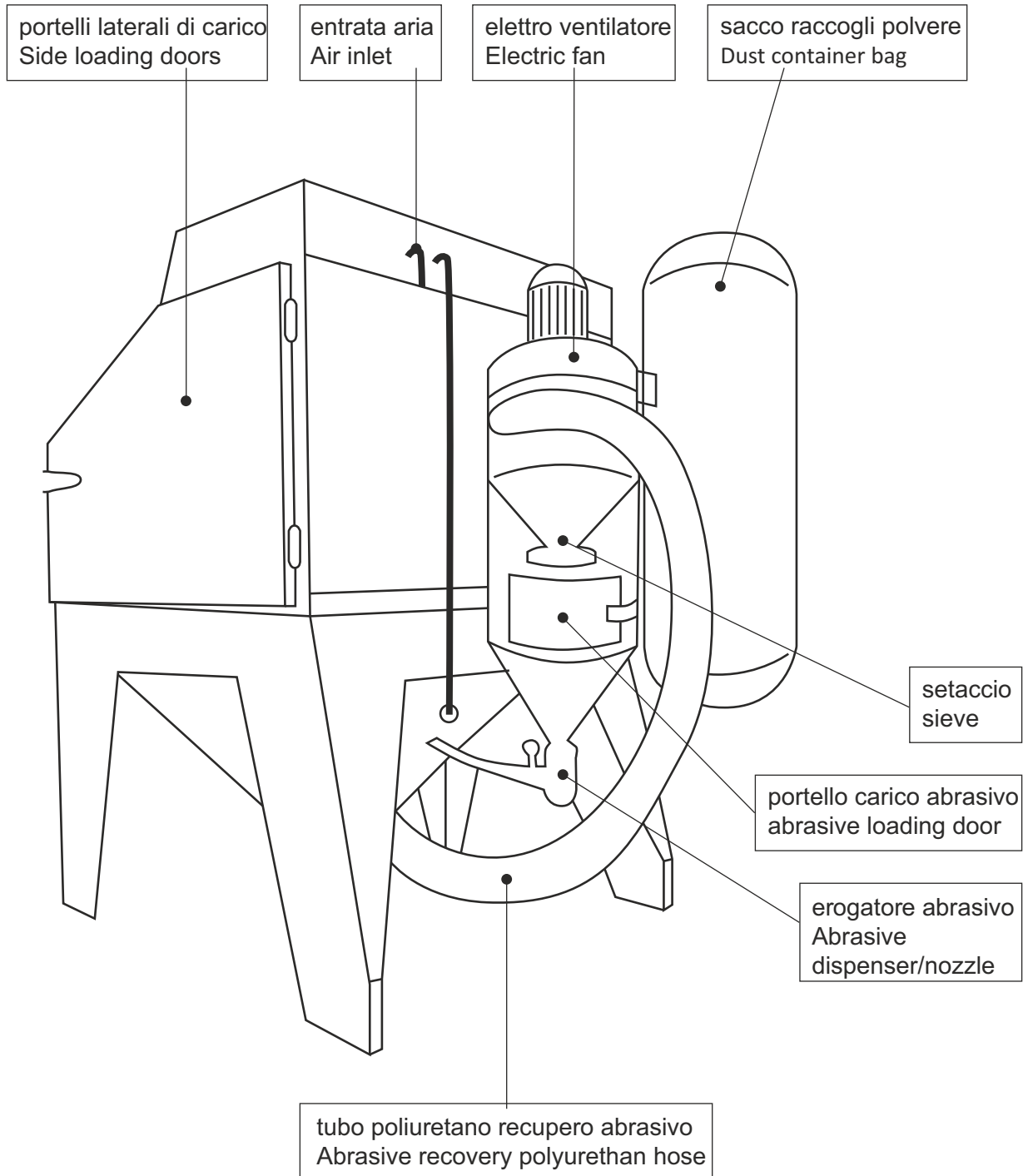

«Colors OK»
Vedi a pag. 11 | See page 11



BOK-AIR-DP-DIS-CR

Cestello rotante motorizzato con quadro elettrico per la gestione dei cicli di sabbiatura. Applicazione compatibile con la cabina BOK-AIR-DP-CAB-740 e BOK-AIR-DP-CAB-1260.

Motorised rotating basket with control pannel for sandblasting cycle control.

Compatible with cabins BOK-AIR-DP-CAB-740 e BOK-AIR-DP-CAB-1260



BOK-AIR-DP-ACC-TR-10CC

Tavola rotante manuale estraibile diam. 500 con carrello di caricamento con pianto basculante L= 1000 per cabina BOK-AIR-DP-CAB-420

Extractable rotating table diam. 500 with charging cart with platform balance L=1000 per cabinet BOK-AIR-DP-CAB-420

BOK-AIR-DP-ACC-TR-11CC

Tavola rotante manuale estraibile diam. 700 con carrello di caricamento con pianto basculante L= 1200 per cabina BOK-AIR-DP-CAB-740

Extractable rotating table diam. 700 with charging cart with platform balance L=1200 per cabinet BOK-AIR-DP-CAB-740

BOK-AIR-DP-ACC-TR-12CC

Tavola rotante manuale estraibile diam. 900 con carrello di caricamento con pianto basculante L= 1600 per cabina BOK-AIR-DP-CAB-1260

Extractable rotating table diam. 900 with charging cart with platform balance L=1600 per cabinet BOK-AIR-DP-CAB-1260



BOK-AIR-DP-ACC-CR-740-1260

Valvola dosa abrasivo di precisione
Abrasive valve with fine regulation



BOK-AIR-DP-ACC-13RG

Rivestimento in gomma antiscivolo per cabina BOK-AIR-DP-CAB-420, BOK-AIR-DP-CAB-740 e BOK-AIR-DP-CAB-1260.

Rubber coating for cabinet BOK-AIR-DP-CAB-420, BOK-AIR-DP-CAB-740 e BOK-AIR-DP-CAB-1260.



BOK-AIR-DP-ACC-55P e BOK-AIR-DP-ACC-55ASP

Serbatoio a pressione da 24 o da 60lt per cabine BOK-AIR-DP-CAB-420, BOK-AIR-DP-CAB-740 e BOK-AIR-DP-CAB-1260.

Pressure tank 24 or 60 lt for cabinet BOK-AIR-DP-CAB-420, BOK-AIR-DP-CAB-740 e BOK-AIR-DP-CAB-1260.

BOK-AIR-DP-CMP

INTEGR^{AM}

Blast-OK

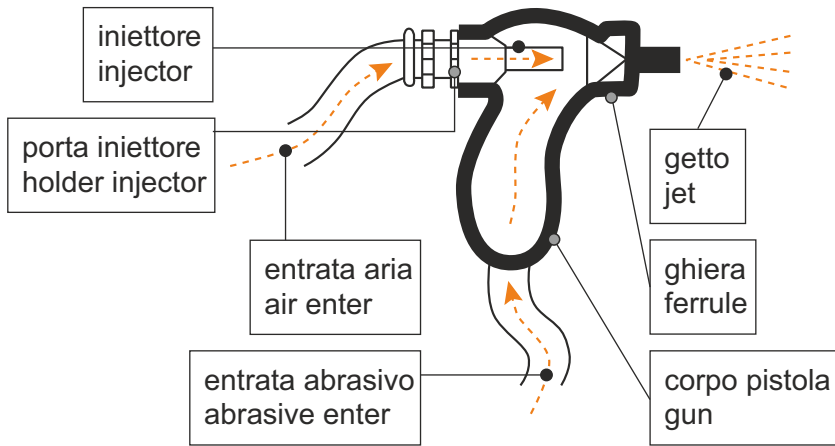

BOK-AIR-DP-CMP-5
Pistola di sabbatura
Sandblasting gun

BLAST-OK

Colors OK



Colors OK, riservati ai settori:

- «Additive Manufacturing» ovvero Fabbricazione Additiva e stampa 3D - post processi
- Micromeccanica, Décolletage, Orologi
- Accessori moda, industria del lusso

Colors OK, reserved for fields of:

- Additive Manufacturing - 3D printing post processing
- Micromechanics, Décolletage, Watches
- Fashion accessories, luxury industry



Colors OK, settori Industriali

Gamma di colori estesa a tutti i settori industriali in genere

Colors OK, Industrial sectors

Color range extended to all industrial sectors in general



Colors OK, «TAILOR MADE»

Gamma di colori su misura per il tuo mercato - a partire da 3+5 unità per modello, da definire.

Colors OK, «TAILOR MADE»

A range of colors tailored to your market - starting from 3+5 units per model, to be defined.

Le foto in questo catalogo sono in **bianco e nero** per una rappresentazione indipendente dal colore e dal settore di destinazione di ciascun prodotto.

The photos in this catalog are in **black and white** for a representation independent of the color and the target sector of each product.



BOK-AIR-CMP

Blast-OK



BOK-AIR-DP-CMP-1
Guanti in lattice antiabrasivo
Antiabrasive Latex gloves



BOK-AIR-DP-CMP-1A
Guanti in neoprene
Neoprene gloves



BOK-AIR-DP-CMP-3
iniettore aria
Air Injector



BOK-AIR-DP-CMP-4
Ugello di sabbiatura
Sandblasting nozzle



BOK-AIR-DP-CMP-7
sacco raccogli polvere
Dust container bag



BOK-AIR-DP-ACC-21
cartuccia filtro
Filter cartridge

Blast-OK



BOK-AIR-DP-DIS-AF-6

Armadio filtro con cartuccia Pulsatron.

Filtro a cartucce mod. **HI-EFFICIENCY "OK1/MV"** autopulente ad aria compressa senza ventilatore, realizzato in acciaio al carbonio.

Cartridge Filter Cabinet with self-cleaning system filter **HI-EFFICIENCY "OK1/MV"** compressed air without fan, made of carbon steel.

Caratteristiche di esercizio PC1/MV

Portata / Capacity

Superficie filtrante totale / Filtering surface total:

Materiale filtrante: cartucce in cellulosa

Cartucce / Cartridges

N° elettrovalvole / Solenoid

Consumo aria compressa / Compressed air consumption

Ventilatore / FAN

Potenza installata / Installed power

Tensione / Voltage

Aliment. ciclico controlavaggio / Aliment, cyclical wash

Cassetto raccogli polvere

Il modello **OK1/MV+** possiede un ventilatore da 1,1 kW con girante maggiorata per l'aspirazione di abrasivi pesanti (graniglie metalliche).

The model **OK1/MV+** possesses a ventilator 1,1 kW with increased impeller for sucking heavy abrasives (metal grit)

Operating characteristics PC1/MV

: 800 m³/h

: 10 m²

Filter cartridges: cellulose material

: 1 cartuccia Ø 325 - h 600 da 10 m² cad.

: 1 elettrovalvola solenoid 3/4 tensione 24/50

: 0,75 Nm³/h

: 0,75 KW

: 0,75 KW

: 400 v

: 24 v dc

Drawer dust

«Colors OK»

Vedi a pag. 11 | See page 11

BOK-AIR-DP-DIS-FD-6

Filtro depolverizzatore con sistema autopulente ad aria compressa e doppia cartuccia filtrante in cellulosa

Sostituisce l'elettroventilatore con sacco raccogli polvere garantendo migliore aspirazione nella cabina ed evitando la dispersione delle polveri esauste nell'ambiente

Consigliato per cabine con volumi importanti, getti di sabbiatura multipli o cicli di lavoro prolungati

Dust collector filter with self-cleaning compressed air system and double cellulose filter cartridge

Replaces the electric fan with dust bag ensuring better suction in the cabin and avoiding the dispersion of exhausted dust into the environment

Recommended for cabins with large volumes, multiple sandblasting jets or long work cycles

Dati tecnici / technical data

Due cartucce 325x600 mm in cellulosa

Accesso laterale (a sinistra e a destra) alle cartucce filtranti

20 m² di superficie filtrante

Portata da 800 a 1900 m³/h

Potenza ventilatore 1,5 kW con coclea

Bocca d'aspirazione 140 mm

Dimensioni 1000x700x1750 mm

Peso 200 kg

Two 325x600 mm cellulose cartridges

Side access (left and right) to filter cartridges

20 m² filtering surface

Flow rate from 800 to 1900 m³/h

Fan power 1.5 kW with screw

Suction inlet 140 mm

Dimensions 1000x700x1750 mm

Weight 200 kg



La gamma di cabine di sabbiatura **BlastOK IntegrAM**, non è solamente una linea standard di prodotti, ma anche molta attenzione a temi come la **SICUREZZA**.

In alternativa ai filtri standard, normalmente montati sulle nostre cabine infatti, possiamo offrire anche soluzioni personalizzate con filtri **ATEX Zona Interna 20**, sia con pulizia a scuotimento manuale che con pulizia automatica in controcorrente di aria compressa. Abbiamo anche sviluppato una polvere inertizzante (**A4**) da miscelare ai BlastMEDIA di ogni tipo, per ridurre il rischio di esplosione in presenza di leghe di Al, Mg, Ti.

The **BlastOK IntegrAM** range of sandblasting cabinets is not just a standard line of products, but also a lot of attention to issues such as **SAFETY**.

As an alternative to the standard filters, normally mounted on our cabins, we can also offer customized solutions with **ATEX Internal Zone 20** filters, both with manual shaking cleaning and with automatic cleaning in countercurrent of compressed air. We have also developed an inertizing powder (**A4**) to be mixed with BlastMEDIA of all types, to reduce the risk of explosion in the presence of Al, Mg, Ti alloys.

Blast-MEDIA

Vasto assortimento a stock
Large sortment available at stock



IntegrAM offre, in alternativa o a completamento di una cabina di sabbiatura classica o evoluta, l'innovativa tecnologia VibroBLAST.

Consultaci per ulteriori informazioni a proposito di questa rivoluzionaria tecnologia!

IntegrAM offers, as an alternative or to complete a classic or advanced sandblasting cabinet, the innovative VibroBLAST technology.

Contact us for more information about this revolutionary technology!

The network of specialists, for **AM professionals**

INTEGR **AM**

**BLAST
OK!**



IT/UK

IntegrAM

The network of specialists, for **AM professionals**

Il programma e il network IntegrAM sono coordinati da:

The IntegrAM program and network are coordinated by:

Techno Surface Sas - Via Po, 12 - IT-20853 Biassono (MB)

Tel. **IntegrAM:** +39 349 29 23 689

e-mail **info@integram.eu**

web **https://integram.eu**

Questa brochure è solo a scopo orientativo. Il suo contenuto può cambiare a seconda dello sviluppo del prodotto.
This brochure is for guidance only. Its content can change depending on the development of the product.

#0124-BlastOK-[I-AM]CA[It-uk]16A4V

